

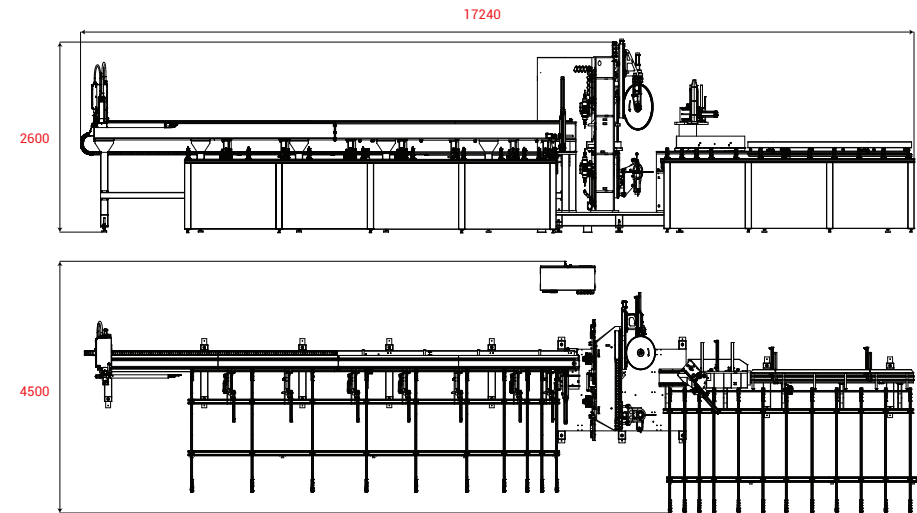







General Features

- Cutting and milling operations of profiles.
- Maximum profile length of entry conveyor is designed to be 8 meters.
- Maximum profile length of exit conveyor is designed to be 5 meters.
- In order to ensure continuous precision, stress relieving method is applied in cast and aluminium pieces.
- Wastes can be evaluated by optimizing automatically within cutting lists.
- Algorithm suitable for minimum waste maximum production principle.
- Profile conveying and positioning, automatic profile recognition feature.
- Cut pieces are automatically transferred to conveyor by exit robot.
- Tool cooling system with speed adjustment of oil-air mixture spraying and liquid level sensor.
- Warning system that prevents incorrect profile placement.
- Periodical maintenance reminder function.
- Easy adjustment of parameters.
- Robust mechanical system suitable for higher speed.
- 6 profiles can be loaded to entry conveyor.
- Automatic greasing system.



ZK 3020

 400 V (50-60 Hz) (kW)	 6-8 bar (l/r/dk)	 kg	 W x L x H (mm)	 L (min.) x L (max.) (mm)	 a x h (mm) Kesim 300 x 250 İçleme 250 x 250	 ØD x Ød x b (mm)	 X x Y x Z (mm)
32	300	10650	17240 x 4500 x 2600	— x 8000	15 x 50	600 x 40 4,4	

Spindle

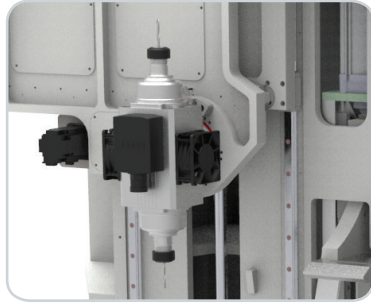
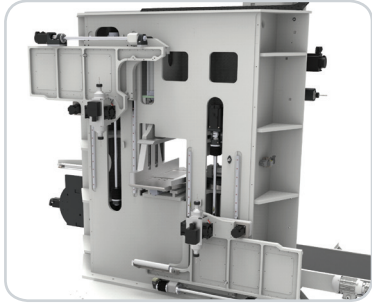

- Servo motor controlled machining unit that enables performing all required actions on four surfaces of piece to be processed.
- Double milling tipped hertz motor in servo controlled 2 separate machining group.
- Angles of machining group moves 360°.
- Max. Machining of profile with 250x250mm dimensions.
- Ability to process on both sides thanks to reciprocal servo motors on milling unit.

Saw

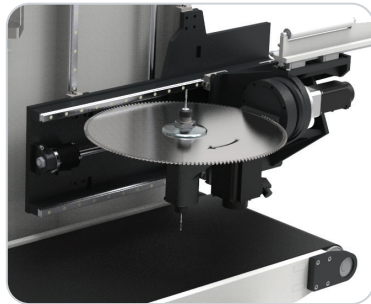
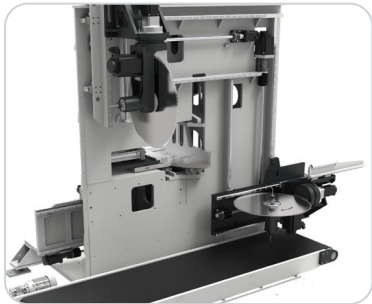

- 2 saws that are Vertically and Horizontally positioned and 0-270° rotatable.
- Aluminium profile is cut by carrying with servo controlled robot.
- Adjustable saw progress speed.
- Saw diameter: Ø600mm
- Saw revolution: 1400 rpm
- Maximum cutting profile dimensions: 300mm (width) x 250mm (height)
- Minimum cutting profile dimensions: 15mm (width) x 50mm (height)

Control Panel



- It communicates with programs that extract .ncx files.
- 19" Industrial PC
- USB and COM Ports.
- Service support via remote connection.